Cimarron Technologies Corporation

MODEL CEU-2 ANI ENCODER

UNIVERSAL ANI – EMERGENCY IDENTIFICATION ENCODER

Dual Mode

GE-STAR® and MDC-1200® COMPATIBLE

Instruction Manual

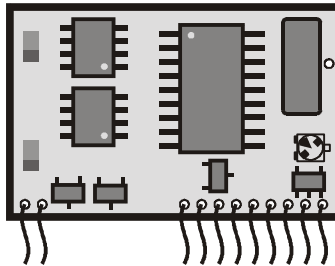

*Copyright 1999 – Cimarron Technologies Corporation, Escondido, CA 92029
All rights in this material are reserved. No part of this document may be reproduced
in any way without the express written permission of Cimarron Technologies Corporation.*

GE-STAR® is a registered trademark of Ericsson.
MCD-1200® is a registered trademark of Motorola Inc.

Manual Number 05 50 0010
Rev C

934 South Andreasen Dr. Suite G
Escondido, CA 92029-1919
(760) 738-3282 California and U.S. (800-487-7184) FAX (760) 480-0233
Email: Cimarron@cts.com

CIMARRON
TECHNOLOGIES

WARRANTY

Cimarron Technologies Corporation warrants this product to be free from defects in material and workmanship for a period of three years from date of shipment. If a malfunction occurs due to defective material or workmanship, the product will be replaced without charge if returned to the factory.

This warranty does not apply to any failure or damage caused by accident, neglect, unreasonable use, improper installation, or to alterations or modifications to the unit. Nor does the warranty extend to damage incurred by force majeure (natural causes) such as lightning, fire, floods, or other such catastrophes, nor to damage caused by environmental extremes, power surges and/or transients.

Cimarron Technologies Corporation makes no other warranty, either expressed or implied, with respect to this product. Cimarron Technologies Corporation specifically disclaims the implied warranties of merchantability and fitness for a particular purpose. Some states or provinces do not allow limitations on how long an implied warranty lasts, so the above limitation or exclusion may not apply to you.

The remedies provided herein are customer's sole and exclusive remedies. In no event shall Cimarron Technologies Corporation be liable for any lost profits, direct, indirect, special, incidental, or consequential damages, whether based on contract, tort, or any other legal theory.

TABLE OF CONTENTS

Identifying the CEU-2	Page 3
Programming the CEU-2	Page 3
Description	Page 4
ANI Message	Page 4
Stuck Mic Message	Page 4
Emergency Message	Page 5
Man-Down Message	Page 5
Status Messages	Page 5
Canned - ID Messages	Page 5
Specifications	Page 6
Field Programmable Alternatives	Page 8
Emergency	Page 8
Open Mic Monitor	Page 9
Man-Down	Page 9
Man-Down Periods	Page 11
Stuck Mic	Page 11
Attack Delay	Page 12
Multi-Function I/O	Page 13
Jumpers	Page 14
Wire Descriptions	Page 15
Quick Start Installation Guide	Page 18
Time Out Timer Application Note	Page 19
Trunking Application Note	Page 20
Block Diagram - Typical Installation	Page 21
Block Diagram - Functional	Page 22
Schematic - CEU-2	Page 23

IDENTIFYING THE CEU-2

The CEU-1 and CEU-2 both look nearly identical. The CEU-2 has a "3" stamped in white ink on the largest IC. Both the CEU-1 and CEU-2 use the same printed circuit board. Do not be confused with the "CEU-1" silkscreen on the rear of the printed circuit board. This silkscreen is not an indication of function.

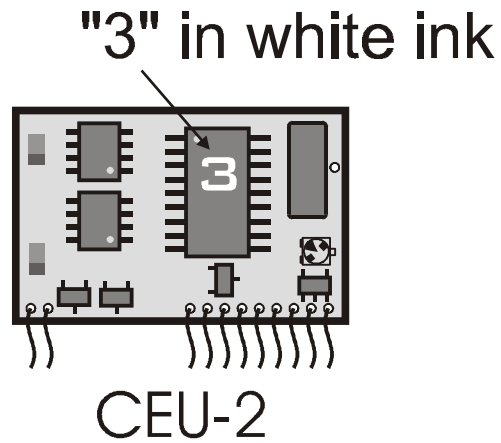

PROGRAMMING THE CEU-2

The CEU-2 must be programmed before installation. All programming is done via the CPF-2 Field Programmer. Please refer to the CPF-2 Operation Manual for instructions.

This manual will explain the hardware connections and configurations of the CEU-2.

DESCRIPTION

The Cimarron Technologies' Model CEU-2, ANI/Emergency ID Encoder is a dual format encoder. The CEU-2 can be programmed to operate in GE-STAR or MDC-1200 modes. The unit provides Automatic Numeric Identification (ANI) of a specific radio transmitter each time the microphone press-to-talk (PTT) switch is activated, and is capable of transmitting three other data messages.

The three additional messages are typically coded as "Stuck-Mic", "Emergency", and "Man-Down".

The Model CEU-2 can also be used as a monitoring or alarm transmission module by programming status and "canned" messages and interpreting them as sensor inputs at the decoding site.

The Model CEU-2 is programmable for General Electric GE-STAR signaling method and format. The signaling format uses Phase Shift Keying (PSK). The format allows for complete flexibility for both one-way and two-way signaling, includes an error detection code, and a signaling protocol to minimize decoding errors and falsing.

The Model CEU-2 is also programmable for the Motorola MDC-1200 signaling format. This signaling format is Frequency Shift Keying (FSK).

The wiring connections are the same for GE-STAR or MDC-1200 installations.

ANI-ID MESSAGE

ANI (Automatic Numeric Identification) provides for digital identification of a transmission initiated by a transmitter's microphone switch ("Press-To-Talk" or "PTT" switch). This "digital burst" can occur when the switch is first pressed, or when the switch is released, or at both times. The burst time for most identifiers is approximately 1/3 second and, if transmitted upon pressing the PTT switch, may obliterate the first one or two syllables of spoken speech. To overcome this annoyance, the Model CEU-2 is programmable to produce the burst either at the beginning, or at the end of the voice transmission, or (better yet) at both times. If programmed for both times, typically the burst at the beginning is programmed to be short, while the burst at the end is programmed to be longer and therefore more reliable. Although the probability of decoding the short burst is decreased, under average signal conditions the probability is still quite high. By following this with a longer burst at the end, the probability of a successful decode is virtually 100%. This programming flexibility is unique to the Cimarron Model CEU-2.

To further guard against voice-syllable clipping, the user may program a "PTT Sidetone". When programmed and interfaced to receiver audio, this feature will provide an audible tone during the transmission of the ANI-ID message burst to alert the operator that a digital burst is being transmitted.

STUCK-MIC-ID MESSAGE

When a mobile or portable radio is inadvertently keyed due to a stuck microphone switch, it generally means that the radio frequency is unusable for communications. Unfortunately, this activity is sometimes deliberately caused by a field operator. By incorporating a Stuck-Mic-ID Message in the Model CEU-2's repertory, each time a microphone switch is held closed for more than a minute either the offending unit's identification is transmitted and a local tone is sounded every ten seconds, or the unit can be programmed to transmit the unit's ID once, sound a local tone, and then automatically open the key line until the microphone switch is released.

EMERGENCY-ID MESSAGE

The Emergency-ID message is generally used by law enforcement, security agencies, and fire departments to automatically signal a life-threatening situation where it is difficult, impossible, or impractical to use voice. The emergency message is also frequently used by business and industrial users to signal a critical situation, such as a mechanical failure, over or under temperature (pressure, etc.), or extraordinary event.

The Model CEU-2 allows for programming the burst length, and whether the message should be a single burst, repeated five times at ten second intervals, or repeated continuously at ten second intervals. In addition, during the emergency cycle the microphone of the sending radio can be monitored, and in the continuous mode can alternate between monitoring and allowing the channel to be used for voice communications. This, too, is a unique benefit of the Model CEU-2.

MAN-DOWN-ID MESSAGE

The Man-Down ID message is primarily for use by law enforcement, security agencies, and fire departments. However it also finds uses in business and industry where individuals can be overcome by toxic fumes, lack of oxygen, etc.

The Man-Down ID is generally initiated by closure of a mercury switch located within a hand-held radio when the radio is continuously tipped greater than 60 degrees from vertical. To guard against false "man-down" transmissions an initial pause of a few seconds during which the closure must be constant is provided. After this duration a short tone is produced via the radio's speaker. A second pause follows the tone to allow the radio to be placed in an upright position (in the event no actual "man-down" is occurring). Following the second pause the "Man-Down-ID" data burst is transmitted in the same manner as the "Emergency-ID", and depending upon programming, providing either a single, repeat, or continuous burst transmission. The Man-Down mode also can include the microphone monitoring alternative. Transmission of a unique coding for the Man-Down message (in lieu of a general Emergency coding), and multiple choices of initiation, tone, and final pause times are special features of the Model CEU-2.

STATUS-ID MESSAGES

Status-ID messages typically relate to the status of the field unit, such as "In Service", "Out Of Service", "On Break", etc. The format can include up to eight of these messages, and their coding configurations can be interpreted as having any meaning at the decoding site. The CEU-2 is capable of transmitting two status messages (or a combination of two status and canned messages) in lieu of the Man-Down and Emergency.

CANNED-ID MESSAGES

"Canned-ID" messages handle such communications as "Request-To-Talk", "Priority-Request-To-Talk", "Repeat Last Transmission", "Repeat Address", "10-4", "Roger", and other routine requests and responses. The format can include several of these messages, and their coding configurations can be interpreted as having any meaning at the decoding site. The CEU-2 is capable of transmitting two "Canned-ID" messages (or a combination of two status and canned messages) in lieu of the Man-Down and Emergency.

SPECIFICATIONS

GE-STAR Mode, [MDC-1200 mode]

TRANSMISSION METHOD

PSK, programmable, 400 or 800 BPS
[FSK only]

UNIT IDENTIFICATION

0001 to 9999 in 16 different formats.
[0001 to 9999]

ANI MESSAGE

50 mS debounce
Burst at Beginning, End, or both Beginning and End

ANI Sidetone

1 KHz during transmission data.

EMERGENCY ALARM MESSAGE

Many programmable modes.

MAN-DOWN ALARM MESSAGE

Triggered by closing of an external mercury switch (tilt sensor). Many programmable modes.

STUCK-MIC TRANSMISSION:

Triggered after PTT switch is activated continuously for 60 seconds. Two alternate methods are programmable.
[Sends Emergency]

BURST LENGTH

The burst length is independently programmable for ANI ID at beginning, ANI ID at end, and one setting for Emergency, Man-Down, and Stuck Mic. 1½, 2½, 3½, or 4½ messages.
[180 mS]

BUSY/CLEAR CHANNEL INPUT

Operates from logic levels of <1 volt and >2 volts up to 5.1 volts max.

MULTI-FUNCTION I/O

This I/O can be programmed to control a CTCSS encoder, or to switch the radio channel of some transceivers, or to inhibit the encoding of any data while an input is active, or to control the audio circuits of transceivers which require a signal to open audio. 10 mA source or sink.

DATA OUTPUT

Capacitively coupled.
Idle: >1 Megohm impedance.
Encode: Adjustable from 0.0 to 150 mV P-P, or from 0.0 to 4.5 V P-P, assuming radio input impedance of 10 K Ohm. Jumper selectable.

KEYING OUTPUT

Open collector transistor. Provides a 300 mA, momentary duty sink during data bursts and a 200 mA continuous duty sink during audible monitor mode. Sink is to within 1 Volt of system negative.

MICROPHONE AUDIO MUTE - OUTPUT

Open collector transistor capable of sinking 300 mA during data transmissions (for pulling down mic audio line in order to mute voice audio which may distort data).

SPECIFICATIONS – cont

ATTACK DELAY

The attack delay is programmable for 125, 325, 625, or 1300 milliseconds.

PREAMBLE LENGTH

Alternating "1"s and "0"s, and is programmable to one of four lengths.
[fixed for MDC1200]

PROGRAMMING

All programmable functions are accomplished by the Model CPF-2 Field Programmer.

Programming can take place while the Model CEU-2 is interfaced to most radios.

RADIO INTERFACE

Flying leads of crush resistant Teflon 26 ga. insulated wires.

SUPPLY VOLTAGE

4.5 to 5.0 regulated VDC or 6.0 to 16.5 VDC unregulated.

SUPPLY CURRENT

With 12 VDC input: 3.5 mA Standby, 35.0 mA when encoding.

TEMPERATURE

Operating: -30°C to +70°C (-22°F to +158°F).

HUMIDITY

0% to 90% (non-condensing).

SIZE

18.75 mm x 28.75 mm x 3.15 mm (0.75" x 1.15" x 0.125").

FIELD PROGRAMMABLE ALTERNATIVES

ANI ID MESSAGE

TRANSMIT TIME: Beginning, End, or Both.

BEGINNING BURST LENGTH: 1½, 2½, 3½, or 4½ messages.

END BURST LENGTH: 1½, 2½, 3½, or 4½ messages.

MESSAGE TYPE: Any other in lieu of ANI ID.

SIDETONE:

Produces audible 1 Khz alert tone via receiver speaker during transmission of ANI-ID data burst.

EMERGENCY ALARM MESSAGE

MESSAGE TYPE:

Can be programmed to any message type in lieu of the Emergency code.

BURST MODE:

Single Message:

The message is transmitted only once when the channel is clear. Generally used if the message is programmed as a Status or Canned Message.

Repeat Message:

W/PTT ANI-ID, W/Out Monitor Mic: The Emergency message is transmitted 5 times and only when the channel is clear.

W/PTT EM-ID, W/Out Monitor Mic: Transmits Emergency every 10 seconds, even if the Channel is busy. The transmitter is un-keyed during the 10 Second pauses. A count is made of clear Channel transmissions. After a count of 5 clear channel transmissions, the Emergency cycle is concluded. Voice can be used during the 10 Sec pauses.

This protocol increases the probability of an early decode and increases the reliability of decoding at the dispatch decoder.

Continuous Cycle:

Regardless of PTT alternative or whether the channel is busy or clear, the Emergency Message is transmitted every 10 seconds with un-keyed pauses between transmissions until power is removed from the radio.

PTT INITIATED MESSAGE:

Normal PTT ANI-ID Message:

During a Repeat or Continuous cycle, each activation of the PTT input results in a normal ANI-ID Message.

Emergency Cycle PTT EM-ID Message:

During an Emergency Repeat or Continuous cycle, each PTT switch actuation will result in the transmission of an additional Emergency Message in lieu of the ANI ID Message.

Continuous PTT EM-ID Message:

After an Emergency cycle is initiated, each PTT actuation will result in an additional Emergency Message until power is removed from the radio.

INPUT POLARITY:

The Emergency switch input is programmable for either a normally open (N.O.) or normally closed (N.C.) switch.

MONITOR OPEN MICROPHONE MODE:

During the Emergency Repeat Cycle the radio is keyed continuously with an open microphone between the five, ten-second spaced Emergency Bursts. NOTE: As the radio is keyed between data bursts, the Channel/Busy circuit will not be operative, and the PTT input is not monitored. A total of five Emergency bursts will be transmitted.

If the Monitor Open Microphone Mode is selected in conjunction with the Continuous Emergency Cycle, the activated radio will first continuously transmit microphone audio between five Emergency bursts (Channel/Busy inoperative, PTT input not monitored). The unit then provides unkeyed pauses between Emergency bursts until a count of five clear channel bursts is made (Channel busy operative and PTT is monitored). The unit then reverts to continuously transmitting between five Emergency bursts, and alternates between these modes until power is removed.

This mode of operation will provide 40 seconds of open-mike monitoring, followed by at least 40 seconds in which emergency bursts with un-keyed pauses will be transmitted, thereby alternately allowing open-microphone monitoring, and possible voice transmissions between bursts on the radio channel.

LOCAL AUDIBLE ALERT TONE:

Tone output is applied to the radio receiver's audio circuit. Programmable On/Off. If On, causes a 1 second tone each time the Emergency Burst is transmitted. If Off, no tone is sounded during the Emergency Mode.

MAN-DOWN ALARM MESSAGE

MESSAGE TYPE:

Emergency Message:

For decoders which cannot recognize the Unique Man-Down code the unit may be programmed to transmit the Emergency code during the Man-Down cycle.

Unique Man-Down Message:

The unit can be programmed to transmit a unique "Man-Down" message in lieu of the Emergency Message. NOTE: The decoder-display must be capable of recognizing the unique message.

Other Message Codes:

May be programmed to be any message type in lieu of Emergency or unique Man-Down codes.

NOTE: If the Emergency and Man-Down inputs are to be used for other messages or as a combination of status (or canned message) and an Emergency, be advised that initiation of the Man-Down input will preempt any message transmissions from the Emergency input. Therefore, if a status (or canned message) and an Emergency are to be used, program the status (or canned) for the Emergency input and the Emergency message for the Man-Down input.

BURST MODE:

Single Message:

The message is transmitted only once. Used if the message is programmed as a Status or Canned Message.

Repeat Message:

W/PTT ANI-ID, W/Out Monitor Mic: The man-down message is transmitted 5 times and only when the channel is clear.

W/PTT MD-ID, W/Out Monitor Mic: Transmits man-down every 10 seconds, even if Chan is busy. Transmitter is un-keyed during 10 Sec. pauses. A count is made of clear Channel transmissions. After a count of 5, the man-down cycle is concluded. Voice can be used during 10 Sec pauses.

This protocol increases the probability of an early decode and increases the reliability of decoding at the dispatch decoder.

Continuous Cycle:

Regardless of whether the channel is busy or clear, the Man-Down Message is transmitted every 10 seconds with un-keyed pauses between transmissions until power is removed from the radio.

PTT INITIATED MESSAGE:

Normal PTT ANI-ID Message:

During a Repeat or Continuous cycle, each activation of the PTT input results in a normal ANI-ID Message.

Man-Down Cycle PTT MD-ID Message:

During a Man-Down Repeat or Continuous cycle, each PTT switch actuation will result in the transmission of an additional Man-Down Message in lieu of the ANI ID Message.

Continuous PTT MD-ID Message:

After the Man-Down state is entered, all further PTT closures will result in a Man-Down Message until power is removed from the radio.

INPUT POLARITY: The input is programmable for either a N.O. or N.C. switch.

MONITOR OPEN MICROPHONE MODE:

During the Man-Down Repeat Cycle the radio is keyed continuously with an open microphone between the five, ten-second spaced Man-Down Bursts. NOTE: As the radio is keyed between data bursts, the Channel/Busy circuit will not be operative, and the PTT input is not monitored. A total of five Man-Down bursts will be transmitted.

If the Monitor Open Microphone Mode is selected in conjunction with the Continuous Man-Down Cycle, the activated radio will first continuously transmit microphone audio between five Man-Down bursts (Channel/Busy inoperative, PTT input not monitored). The unit then provides unkeyed pauses between Man-Down bursts until a count of five clear channel bursts is made (Channel busy operative and PTT is monitored). The unit then reverts to continuously transmitting between five Man-Down bursts, and alternates between these modes until power is removed.

This mode of operation will provide 40 seconds of open-mike monitoring, followed by at least 40 seconds in which Man-Down bursts with unkeyed pauses will be transmitted, thereby alternately allowing open-microphone monitoring, and possible voice transmissions from other units between data bursts on the radio channel.

MAN-DOWN INITIATION PERIODS: Eight (8) initiation time periods are programmable:

<u>Initiation Time</u>		<u>Tone Time</u>	<u>Pause Time</u>
0.050	Sec	n/a	n/a
5.0	Sec	1 Sec	2 Sec
5.0	Sec	1 Sec	5 Sec
10.0	Sec	1 Sec	10 Sec
10.0	Sec	1 Sec	20 Sec
10.0	Sec	1 Sec	30 Sec
10.0	Sec	1 Sec	45 Sec
10.0	Sec	1 Sec	60 Sec

The first selection would be used if the Man-Down input is used to initiate a status or canned message.

LOCAL AUDIBLE ALERT TONE:

Output is applied to radio receiver audio circuit. Programmable On/Off.

STUCK-MIC TRANSMISSION:

MESSAGE TYPES:

ANI-ID Message:

For decoder/display units which do not recognize the Unique Stuck-Mic code, the ANI ID code may be programmed for the Stuck-Mic cycle.

Unique Stuck-Mic Message:

A unique "Stuck-Mic" message code may be transmitted in lieu of the ANI ID Message code. NOTE: The decoder-display in use must be compatible with the unique message code.

Other Message Codes:

May be programmed to be any message type in lieu of ANI ID or unique Stuck-Mic codes.

STUCK-MIC PROTOCOL:

The Stuck-Mic protocol is disabled during the Emergency and Man-Down cycles.

Ten-Second Repeat:

The Stuck-Mic message is transmitted every 10 seconds until either the PTT switch is released or power is removed from the radio. If the tone output is interfaced to the radio receiver's audio circuit, a one second tone will be sounded each time the ANI burst is transmitted.

Time-Out-Timer:

If the PTT line is wired through the identifier, the unit may be programmed such that after 60 seconds of continuous keying the unit will transmit one digital message, the PTT line will be opened, and if the tone output is applied to the receiver's audio circuit, an audible tone will be sounded for one second. The PTT line will remain open until the PTT switch is released, an Emergency or Man-Down mode is entered, or power is removed from the radio.

BURST LENGTH

In general, the longer the burst length the higher the probability of decoding a digital message, thereby resulting in better reliability of data transfer. However, a long burst for beginning ANI ID may cut-off a voice syllable. A compromise can be made by using a short burst for a "beginning" ANI-ID and a long burst for an "end" ANI-ID.

The burst length is independently programmable for ANI ID at beginning, ANI ID at end, and one setting for Emergency, Man-Down, and Stuck Mic.

ANI-ID BURST LENGTH:

The Burst Length may be independently programmed for beginning and end ANI-ID to 1½, 2½, 3½, or 4½ messages.

BURST LENGTH FOR ALL OTHER MESSAGES:

Either 3½ or 4½ messages as a group.

ATTACK DELAY

The attack delay provides time for a transmitter to reach full power and for all system audio circuits to open prior to transmission of data. Programmable to 125, 325, 625, or 1300 milliseconds.

PREAMBLE LENGTH

The message preamble aids in bit synchronization. Shorter preambles are used in good signal conditions, while longer preambles allow synchronization in marginal signal conditions. Programmable for 16, 24, 32, or 40 preamble bits.

BUSY/CLEAR CHANNEL INPUT

INPUT SENSE: Input sense for Channel Busy, programmable for logic Hi or Low.

MULTI-FUNCTION I/O

CTCSS CONTROL OUTPUT:

Controls a radio transmitter's CTCSS Encoder "On-Off" to provide "digital muting" in some systems. Idle state is $+5 \pm 0.1$ VDC at 39 K Ohm impedance. Active state occurs during all data burst transmissions and sinks up to 10 ma from a 5 volt source to within 1 Volt of ground.

ALTERNATE CHANNEL OUTPUT:

Provides an output which can change the radio channel in some transceivers during Emergency and Man-Down data transmissions. Idle state is $+5 \pm 0.1$ VDC at 39 K Ohm impedance. Active state sinks up to 10 ma from a 5 Volt source to within 1 Volt of ground.

SIDETONE CONTROL OUTPUT:

Provides an output for transceivers which require a signal to enable the receiver's audio circuits. Idle state is $+5 \pm 0.1$ VDC at 39 K Ohms impedance. Active state occurs during sidetone outputs and sinks up to 10 ma from a 5 Volt source to within 1 Volt of ground.

INHIBIT DATA ENCODE INPUT:

The signal for this input is typically taken from the radio transceiver's channel selector or channel switch (when possible) in order to inhibit data transmissions when in a simplex "Talk Around" mode or on a channel which does not accommodate data. Can also be used to hold ANI data transmissions when a scrambling module is installed in the radio. Input provides pull-up ($+5 \pm 0.1$ VDC) and is programmable to accommodate either an active high or active low input to inhibit data encoding.

JUMPERS

JUMPER CONFIGURATION

The Model CEU-2 is supplied with Jumpers J1 and J2 installed. J3 and J4 are not jumpered. These jumpers are easily cut with a scalpel, razor blade, or other similar device. To install J3 use a fine copper wire and an isolated, 15 Watt soldering iron. The "as supplied" configuration provides:

- Microphone Switch Operation Without Time-Out-Timer
- Radio PTT Switch to Ground for Key
- Low power data output (0v to 150v PP)

Jumper J1

Microphone Switch Operation Without Time-Out-Timer

Leave Jumper J1 connected.

Microphone Switch Operation With Time-Out-Timer

Cut Jumper J1.

NOTE: Also see Time-Out-Timer Application Note on Page 11 and Time-Out-Timer Selection (CEU-2 Programming Manual).

Message Initiation From External Switch

Cut Jumper J1.

Radio PTT sense high but KEY to ground

If the interface requires the CEU-2 to detect when the radio is keyed by the presence of a voltage above 4.5 VDC, cut Jumper J1 and program the PTT Input for ActOpn input sense. (See page 20 of the CPF-2 Operation Manual). In this situation, also interface the Brown "KEY" wire to a point in the radio which goes to ground when keying the radio.

Jumpers J2/J3

Radio PTT Switch Active Low Below 4.5VDC, Inactive High but Not Greater Than 16.5VDC

Leave Jumper J2 connected, J3 open.

Radio PTT Switch Active Low Below 1.0VDC, Inactive High but **Not Greater Than 5.0 VDC**

(This will connect radio PTT directly to the CEU-2 microprocessor)

Cut Jumper J2, connect Jumper J3, set PTT active high (see CEU-2 Programming Manual).

Jumper J4

Data Output Adjustable From 0.0 to 150mV P-P

Leave Jumper J4 disconnected.

Data Output Adjustable From 0.0 to 4.5V P-P

Install Jumper J4.

Some radios may require the maximum voltage level at DATA OUT to deviate to ± 3.5 to ± 4.0 kHz. A small wire jumper carefully soldered across J4 will rail the maximum output level to nearly 5V P-P.

The exact peak-to-peak level will be determined by the characteristics of the point in the radio to which DATA OUT is interfaced.

WIRE DESCRIPTIONS

<u>Signal</u>	<u>Color</u>	<u>Description</u>
A+	Red	Positive supply voltage to the CEU-2. Regulated or Unregulated +6 to +16.5 VDC. If only +5 VDC is available, place a jumper on the back of the CEU-2 between the A+ pad and the 5 VDC pad is located above the A+ pad.
A-	Black	Supply ground.
Aud Inhib	White	Audio Inhibit Output - This line is used to disable the microphone during data transmission time. This is an open collector output and is at high impedance when idle and sinks to within 1 volt of system ground (300 mA max) during data transmission. Usually interfaced to Mic High.
KEY	Brown	Key Output. This line keys the radio when required by the CEU-2. It can be isolated from the PTT input line (see below) by cutting Jumper J1. This is an open collector output and is high impedance when idle and sinks to within 1 volt of system ground when active. It should be connected to a point on the radio which when grounded will key the radio.
PTT	Yellow	<p>PTT input. This line is used by the CEU-2 to detect when the radio has been keyed. The signal is buffered before being sent to the microprocessor. As shipped, a signal of between 4.5 VDC and 16.5 VDC is interpreted as unkeyed. A level below 4.5 VDC is interpreted as keyed. If the radio line is near or below 4.5 VDC and drops to below 1 volt during PTT, cut Jumper J2, install Jumper J3, and set PTT for "Active Open". This brings the interface directly to the microprocessor.</p> <p>Remember <u>+5 VDC MAXIMUM!!</u></p> <p>Jumper J1 connects this line to the Key line and in most installations should remain intact. However, if the installation requires a PTT sense that goes high during PTT, Jumper J1 should be cut and PTT input programmed for "Active Open".</p> <p>If the Time Out Timer feature is desired, cut Jumper J1. In this mode, the radio PTT keys the CEU-2 which in turn keys the radio. This gives full PTT control to the CEU-2. The CEU-2 microprocessor forces the KEY line to follow the radio PTT line. If, however the radio remains keyed for over 60 seconds, the CEU-2 transmits a TOT Message and then unkeys the radio.</p>
Sidetone	Orange	<p>Capacitively coupled 1 Khz 5 Vpp signal output. Too be interfaced to the radio audio amplifier input. A point should be selected that is not affected by the radio volume control. The CEU-2 microprocessor activates this tone line under the following circumstances.</p> <p>If programmed for tone on PTT, this line will be active for the duration of the transmitted ANI data. This gives the operator audible notice when the ANI burst is finished and un-clipped speech is possible.</p> <p>If programmed for tone on Emergency or Man Down, this line will be active as described in the applicable sections.</p>

WIRE DESCRIPTIONS- cont.

<u>Signal</u>	<u>Color</u>	<u>Description</u>
Emergency	Green	Emergency message input from external switch. This line is normally pulled high and grounding it activates the emergency condition. The sense can be reversed by programming the CEU-2 as desired. If the switch is greater than 6" from the CEU-2, greater RF immunity can be obtained by keeping this line grounded and removing the ground via a N/C switch to activate the emergency. In this case, the sense would be programmed for Normally Closed. This line can alternately be used as a status or canned message.
Man-Down	Blue	Man Down message input from external sensor or switch. This line is normally pulled high and grounding it activates the Man Down condition. The sense can be reversed by programming the CEU-2 as desired. Like the Emergency line, this line can also be used as a status message or canned message.
Aux I/O	Grey	<p>Auxiliary input/output. Can be programmed to perform one of the following four functions.</p> <ol style="list-style-type: none"> 1. Transmit Control. Idle state is +5 VDC. Active state occurs during all data burst transmissions. When active, it sinks a maximum 10 mA to within 1 volt of system ground. Typically used to control a transmitter CTCSS, turning it off during ANI transmissions. 2. Home Control. Similar to Transmit control but can be programmed active only during Emergency or Man Down data transmissions. Typically used to change the radio channel to a "Home" channel before sending the Emergency or Man Down message. 3. Tone Control. Idle state is +5 VDC. Active during sidetone outputs. When active, it sinks a maximum 10 mA to within 1 volt of system ground. Used to enable receiver audio circuits to allow amplification of the Sidetone signal. 4. Data Inhibit Control. An input to the CEU-2 microprocessor. Will put the CEU-2 to "sleep" when active. Active state is programmable for logic 1 or 0.
Chan Busy	Violet	Channel Busy input. Provides the CEU-2 the status of the interfaced radio. When in conventional mode, the line should be interfaced to a COS or squelch line which changes state when receiving. This effects the manner in which the CEU-2 handles the Emergency and Man Down transmissions. See the appropriate section for details.
Data Out	White/Black	Capacitively coupled ANI data output. To be connected to the radio transmitter microphone audio, between the pre-emphasis filter and the limiter. As shipped, the output is adjustable from 0.0 to 150 mVpp. Installing Jumper J4 increases the output to a maximum of 4.5 Vpp.

PHYSICAL INSTALLATION

Find a location in the radio for the Model CEU-2, preferably away from the transmitter output amplifier stage. Place the insulating sleeve over the CEU-2 module. Locate the interface points for the CEU-2 interface wiring, cut appropriate wires and solder to radio interface points. Remove interface wires which are not needed.

Adjust R12 (10 K Ohm potentiometer) to provide a data deviation to match the voice deviation (± 3.5 kHz is typical).

Appendix A - Quick Start Installation Guide

The QPF field programmer has a provision to automatically load a standard set of parameters as the "default" program. After installing the "ANIPROG" software, and connecting the serial cable, the QE-2 is ready to be configured. If these default settings are correct for your application, you can follow the simple steps below.

1. Select the Unit ID

Insert the QE-2 into the QPF programmer. Follow the Software Menus to install the default parameters with an ID that you choose for this unit.

QPF Programmer

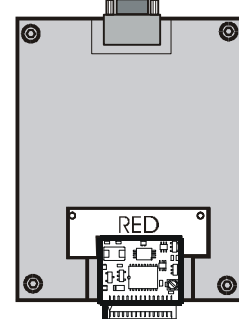

2. Interface the Radio (non-Trunking)

Find the interface points described below in your radio and connect them to the QE-2.

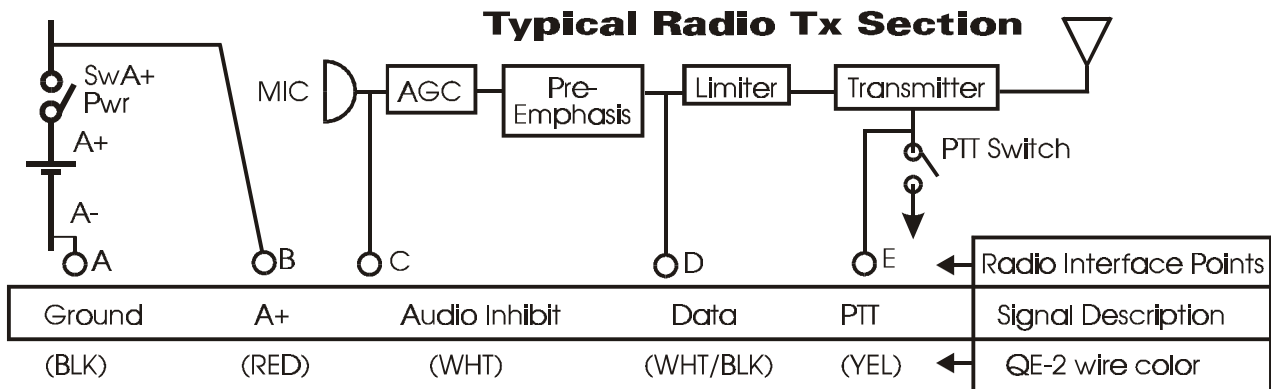

3. Adjust the QE-2

While repeatedly keying the radio into a service monitor, adjust potentiometer VR1 for minimum +/- 3.5 KHz deviation.

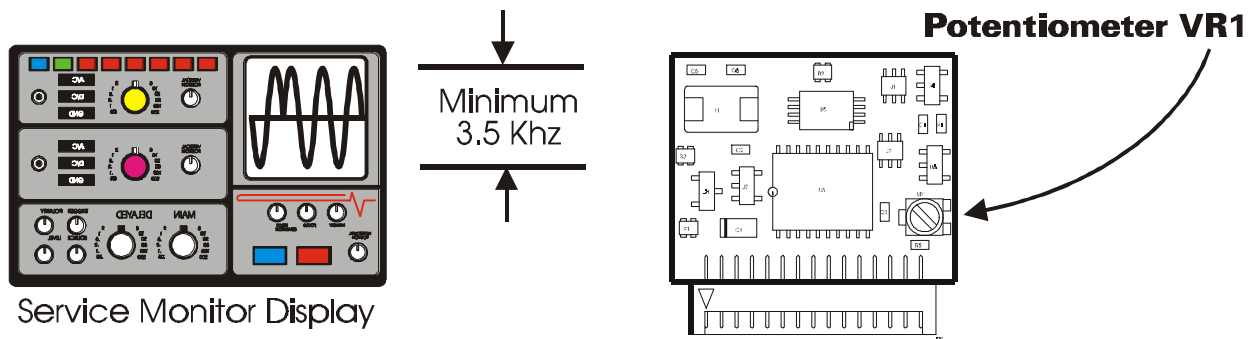

4. Secure the QE-2 Inside Your Radio

Insert the adjusted QE-2 into the insulating sleeve and secure it with the foam tape as required. Close up the radio and verify that the QE-2 is not mechanically stressed and that the wires are not pinched.

Appendix B - Time Out Timer Application Note

GENERAL- The QE-2 is equipped with a time-out-timer (TOT) option. When selected via the QPF Programmer, the TOT option monitors the radio's PTT switch. When the PTT is activated for over 1 minute, the encoders send a unique TOT data message (also selected via the QPF) and then unkeys the radio until the PTT switch is released. The installation of the TOT option is described below.

QPF Programmer

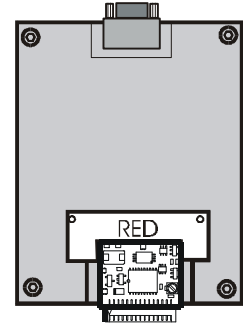

1. **Select** the Time-Out-Timer option when programming the QPF (Refer to the QPF Programming Software).
2. **Cut** Remove jumper K on back of the QE-2 to separate the PTT and KEY lines.

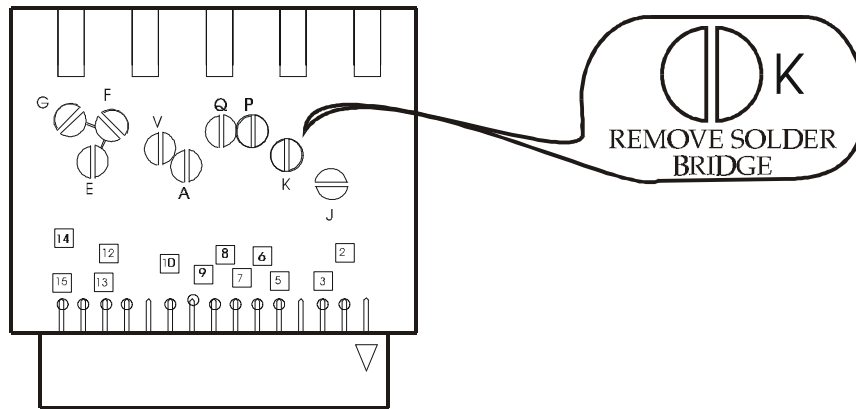

3. **Install** in a radio, with KEY and PTT lines in series with the radio PTT switch.

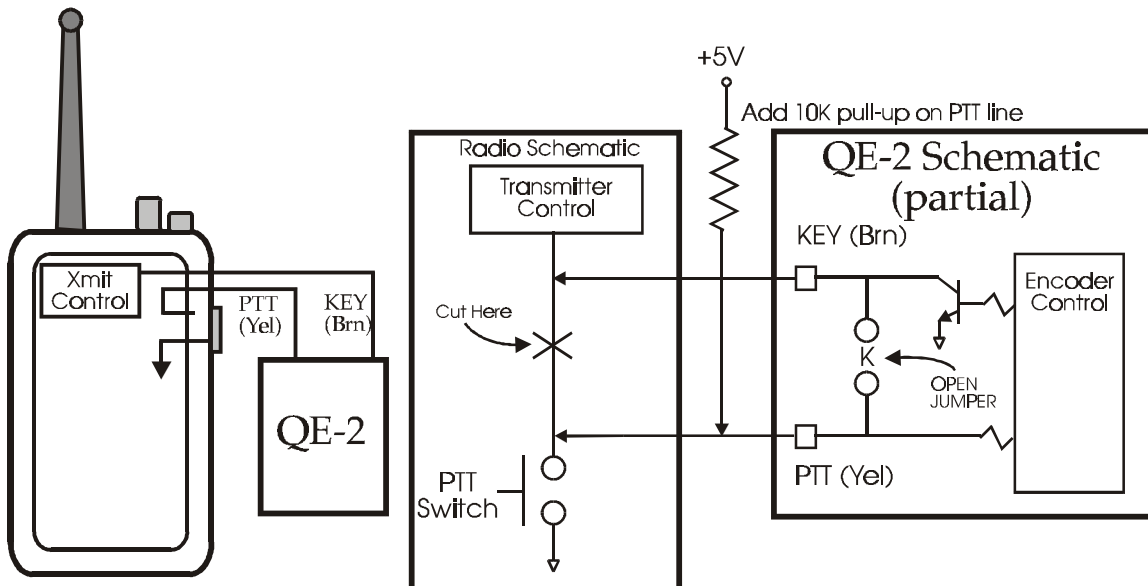

4. **Refer** to the QE-2 Operation Manual installation instructions.

Appendix C - Trunking Application Note

To provide 100% trunking access, the QE-2 can be programmed with one of four (4) debounce periods via the QPF programmer. The unit, when installed as below, will not transmit data until the specified time period has been exceeded. If channel acquisition is not achieved within (2) seconds, the unit will reset, awaiting retry of PTT or other data message.

1. Connect the units CH BUSY (vio) wire to a point in the trunking radio that goes from 0 to +5v or +5v to 0 upon trunking channel acquisition. (See Example)
2. Program the unit with the desired debounce time as below.
3. Select "Conventional" or "Trunking" operation

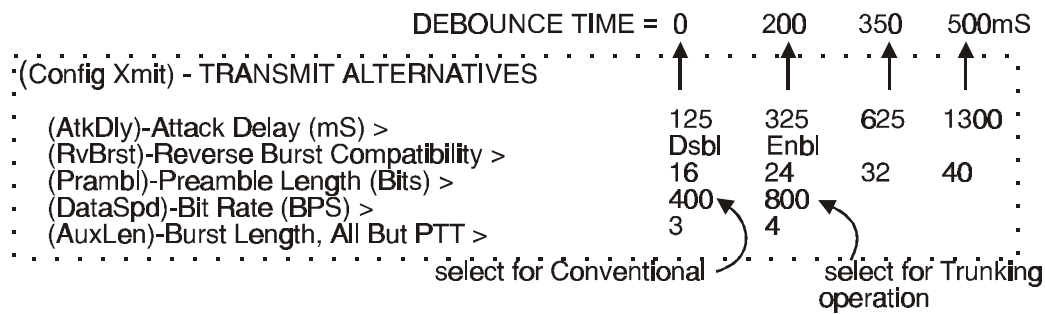

4. Select the channel acquisition voltage sense connected to the CH BUSY (vio) wire.

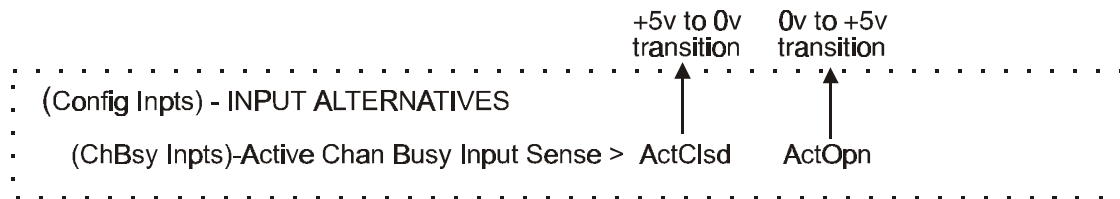

Example:

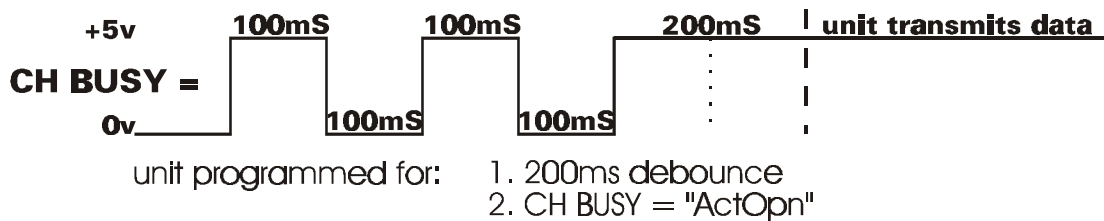

Appendix D – Block Diagram, ANI Installation In A Typical 2-Way Radio

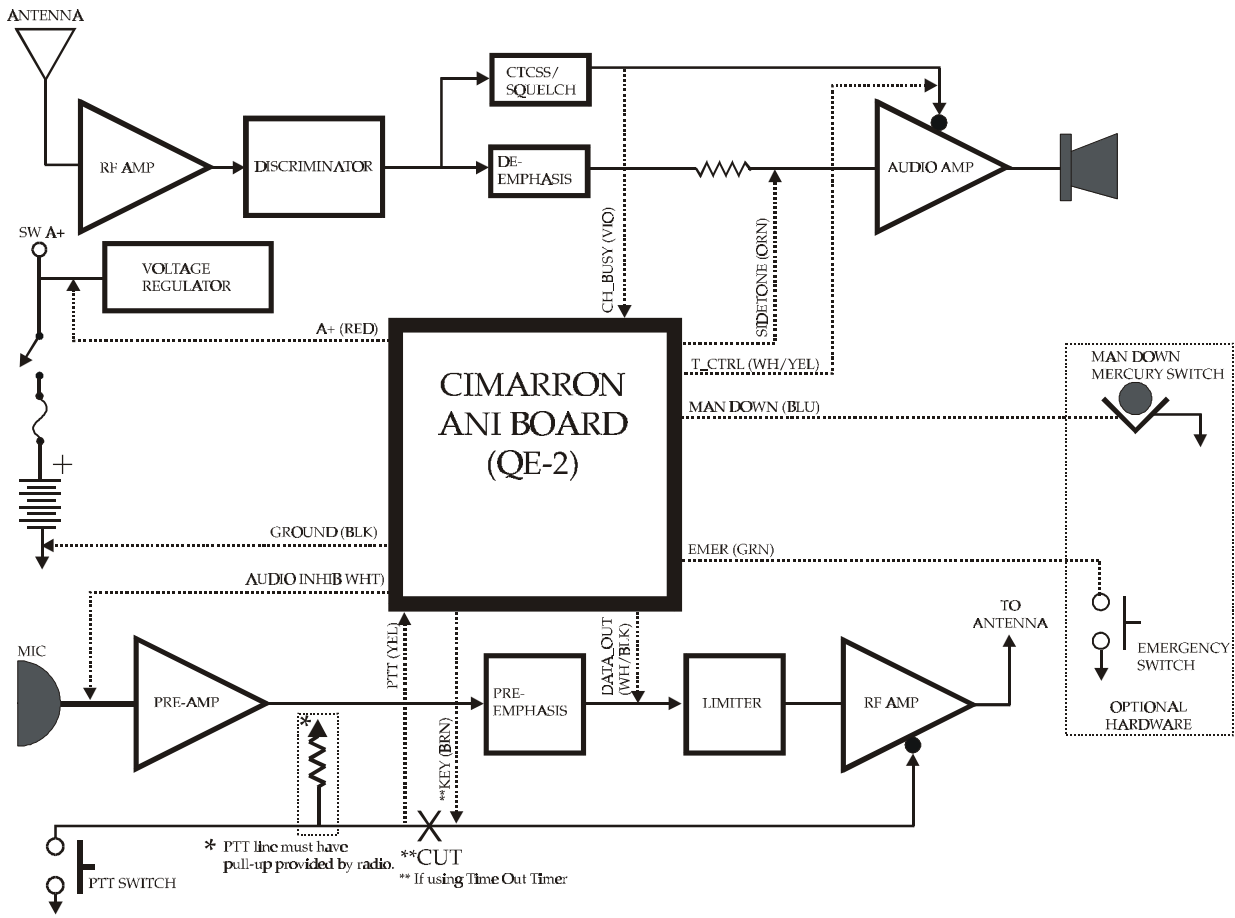

Appendix E - CEU-2 Schematic

REV	DESCRIPTION	BY/DATE
A	PRODUCTION RELEASE W/ B/M/RZ RESON	SH/G-1-99
B	CHANGE WARNING AND NOTE 1, ADD NOTES 2 AND 3.	SH/G-23-99

